

Motion Sensor



Figures 1

User Manual

Preface

As this is the full User Manual, a working knowledge of Z-Wave automation terminology and concepts will be assumed. This manual will provide in-depth technical information about the Motion Sensor, especially in regard to its compliance to the Z-Wave standard (such as compatible Command Classes, Association Group capabilities, special features, and other information) that will help you maximize the utility of this product in your system.

Table of Contents

Description & Features	4
Specifications	5
Network Operation	8
LED Behavior	9
Button Behavior	9
1 Library and Command Classes	10
1.1 Embedded SDK	10
1.2 Device Type	10
1.3 Role Type	10
2 Association Groups	11
Basic CC does not map to any Command Class	12
3 Wakeup	12
4 Battery	12
5 Multilevel Sensor	12
6 Notification	12
7 Manufacturer Information	13
8 Configuration	13
(Param 3) Motion Retrigger and Untrigger Time	13
(Param 4) Motion Sensitivity	13
(Param 5) Motion Report Type	13
(Param 7) Motion Group Control (Group2)	14
(Param 8) Motion Group Value Setting	14
(Param 9) Motion Group Control Requirement	14
(Param 10) Over Heat Group Threshold (Group3)	14
(Param 11) Under Heat Group Threshold (Group4)	14
(Param 12) Over Light Group Threshold (Group5)	15
(Param 13) Under Light Group Threshold (Group6)	15
(Param 14) Low Battery Threshold	15
(Param 15) Threshold Check Enable/Disable	15
(Param 16) Temperature Threshold	15
(Param 17) Lux Threshold	15
(Param 18) Threshold Check Time	16
(Param 19) Sensor Limit Control	16
(Param 20) Temperature Upper Limit	16
(Param 21) Temperature Lower Limit	16
(Param 22) Lux Upper Limit	16
(Param 23) Set lux lower limit level	16
(Param 24) Temperature Scale	17
(Param 25) Automatic Interval Time	17
(Param 26) LED Activity	17
(Param 27) Motion Sensor Report Indicator	17
(Param 28) Temperature Offset Value	17
(Param 29) Lux Offset Value	17
9 Security Network	18

Description & Features



Figures 2

This product can be included and operated in any Z-Wave™ network with other Z-Wave™ certified devices from other manufacturers and/or other applications. All non-battery-operated nodes within the network will act as repeaters regardless of vendor to increase the reliability of the network.

Key Features:

- » Z-wave 800 series design, support Z-wave LR and compatible with Z-wave Mesh.
- » Magnetic attraction and universal rotation
- » Up to 8 meters infrared detecting distance, and wide angle range of 120°.
- » Ambient Light Sensor
- » Air Temperature Sensor
- » 1 mile under LR mode, up to 200 feet under Z-wave mesh mode.
- » Low Battery Indication, CR123A battery Easier to buy and replace.
- » Good to install on wall, intended for residential as well as commercial applications.

Specifications

Radio protocol	Z-Wave(800 series) EFR32ZG23A010F512IM32-BR
Power Supply	CR123A 3.0V Battery
Sleep Current	15 uA
Power LED	RGB LED
Communication Frequency	868.40MHz, 869.85MHz (EU) 908.40MHz, 916.00MHz ,912.00Mhz, 920.00MHz(US)
Communication Range	Z-wave Mesh up to 200 feet. Z-wave LR mode 1 mile.
Operational Temperature	32—158 °F (0—70 °C)
Operating Humidity	8% to 80%

Physical Characteristics

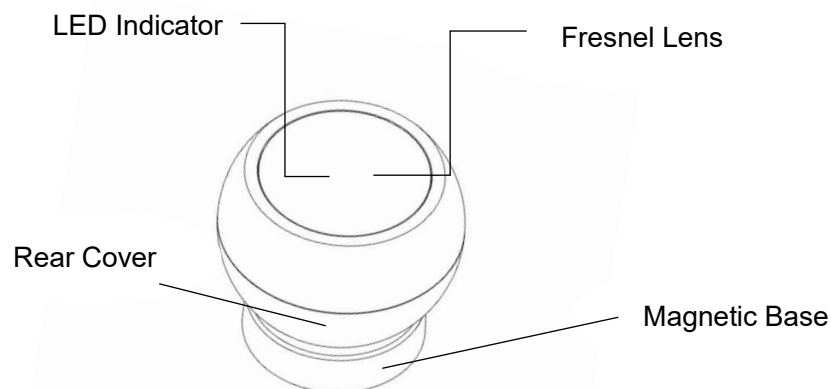

Figure 1

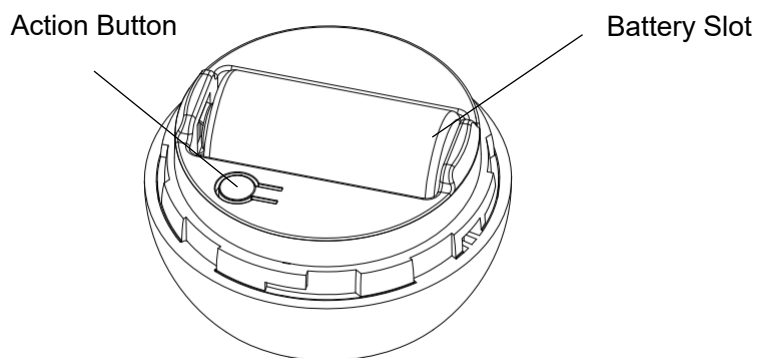

Figure 2

Optimally Installing MultiSensor

MultiSensor has been designed to be mounted on the coner of the wall indoors. To optimally install it, please note the following.

- MultiSensor should NOT be installed in areas of artificial temperature change that would impact the accuracy of the sensors. When selecting a location, avoid placing it beside or near air conditioners, humidifiers, and heaters, and avoid positioning it directly opposite a window or direct sunlight.
- For optimal performance, your MultiSensor should NOT be mounted directly on or near metal framing or other large metallic objects. Large metal objects may weaken the Z-Wave wireless signal.
- Ensure there're no obstacles in front of the lens of MultiSensor. Otherwise, the detection result may be inaccurate.
- Install the sensors where persons may be detected to cross. The double sided tape and screws are optional to be used to fix the Magnetic Base on the wall. Recommend to place the sensor approx 2.5 meters above the ground. As shown on below figure 4 and figure 5.

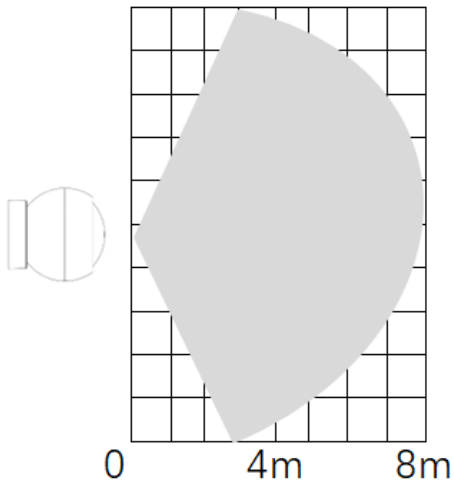

Figure 3

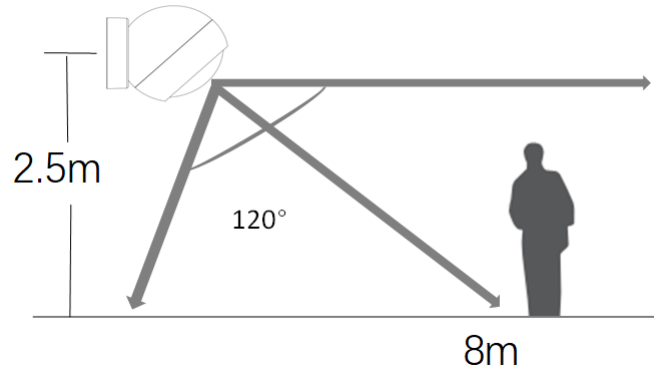

Figure 4

Power MultiSensor

- Turn the Rear Cover counter-clockwise and open it.
- Place the CR123A battery in the battery slot to power on your MultiSensor, pay attention to the positive and negative polars. When MultiSensor is powered on, the LED indicator will blink green once and then colourful gradient alternately.

Adding(Inclusion)

Follow the instructions for your Z-Wave Certified Controller adding inclusion mode. When prompted by the controller.

1. The MultiSensor should be within 10' of your Z-Wave controller for the inclusion process. After successful pairing, the device can be brought to the desired location.
2. Set the main controller into (security/non-security) adding mode (see the controller's manual).
3. Press the Action Button 3 times for device inclusion. The LED Indicator will flash green five times indicating inclusion successful, then it fails to be included, you need to repeat the above process.
4. If your Z-Wave gateway support SmartStart: scan the QR code on MultiSensor using the gateway's app. Your sensor will join your Z-Wave network automatically.

Network Operation

Inclusion

Follow the instructions for your Z-Wave Certified Control to enter inclusion mode. When prompted by the controller:

1. The Motion Sensor should be within 10' of your Z-Wave controller for the inclusion process. After successful pairing, the device can be brought to the desired location.
 2. Remove the MAIN BODY COVER by twisting it apart counter-clockwise.
 3. Remove the BATTERY TAB.
 4. Press the ACTION BUTTON quickly **3 times** for inclusion.
- The INDICATOR LED will flash five times indicating inclusion.

Exclusion

Follow the instructions for your Z-Wave Certified Control to enter exclusion mode. When prompted by the controller:

1. Remove the MAIN BODY COVER from the MAIN BODY BASE.
2. Press the ACTION BUTTON quickly **3 times** in a row.

The INDICATOR LED will flash five times indicating exclusion/disconnection.

Factory Reset & Misc. Functions

Resetting the Multi-Sensor

If needed, the Motion Sensor can be reset locally by following these steps. Only do this when your Z-Wave controller is disconnected or otherwise unreachable. Beware that resetting your device will disconnect it from the system:

1. Remove the MAIN BODY COVER and confirm that your Motion Sensor is powered up.
2. Press and hold ACTION BUTTON for **12 seconds** then release. Flashing light with two colors indicates a successful factory reset.
3. The Motion Sensor's memory will be erased to factory settings.

Waking Up the Multi-Sensor

Because the Multi-Sensor is a battery-powered device, it wakes up at regular intervals to give battery and other status updates to the controller, as well as to accept configuration settings from the controller. This helps to extend the battery life. The device can be forced to wake up to submit these reports or accept new settings immediately by simply pressing and holding the BUTTON for **3 seconds**. The LED INDICATOR will flash once indicating a successful wake-up.

LED Behavior

Color	Behavior
Colorful	Blink green once and then colourful gradient alternately
Red	Blink red 5 times in 2.5 seconds (fast), Blink 4 cycles
Green	Blink Green 5 times in 2.5 seconds (fast)
Red and Green	Blink red and Green alternately in 5 seconds (slow)
Red	Blinks once when the device didn't in any network
Green	Blinks once when the device included

Button Behavior

Action	Condition
Press and hold CONNECT BUTTON for 3 seconds	Sensor already Included in System
Push CONNECT BUTTON 3 Times	Sensor already Included in System
	Sensor already Included, and Controller is in Exclusion Mode
	Sensor Not Yet Included in System, and Controller is in Inclusion Mode
Press and hold CONNECT BUTTON for 12 seconds	Sensor Already Included in System
Press and Hold for 12 seconds	Any condition (as long as the device has power)

1 Library and Command Classes

1.1 Embedded SDK

7.18.3

1.2 Device Type

Generic Device Class: GENERIC_TYPE_SENSOR_NOTIFICATION (0x07) Specific Device Class: SPECIFIC_TYPE_NOTIFICATION_SENSOR (0x01)

1.3 Role Type

Reporting Sleeping Slave (RSS): ROLE_TYPE_SLAVE_SLEEPING_REPORTING (0x06)

1.4 Command Class

Command Class	Version	Not added	Non-secure added	Securely added	
				Non-secure CC	Secure CC
Z-Wave Plus Info	2	Support	Support	Support	
Association	2	Support	Support		Support
Association Group Information	3	Support	Support		Support
Multi-Channel Association	3	Support	Support		Support
Battery	1	Support	Support		Support
Binary Sensor	2	Support	Support		Support
Multilevel Sensor	11	Support	Support		Support
Notification	8	Support	Support		Support
Application Status	1	Support	Support	Support	
Configuration	4	Support	Support		Support
Transport Service	2	Support	Support	Support	
Version	3	Support	Support		Support
Wakeup	2	Support	Support		Support
Manufacturer Specific	2	Support	Support		Support
Device Reset Locally	1	Support	Support		Support
Indicator	3	Support	Support		Support
Power Level	1	Support	Support		Support
Security 0/2	1	Support	Support	Support	
Supervision	1	Support	Support	Support	
Firmware Update Meta Data	5	Support	Support		Support

2 Association Groups

The device supports 7 association groups and every group supports max 5 associated nodes.

Group 1 is Lifeline group, all nodes which associated in this group will receive the messages sent by device through Lifeline.



When Basic CC/ Switch Binary CC are used to control this device or sent through association groups to control other associated nodes, the variable will be phased as the follow ways:

0x01~0x063/ 0xff means On, 0x00 means Off, other values will be ignored.

The Command Class supported by each association group is shown in the table below:

Root Device

ID	Name	Nodes	Profile	Description
1	Lifeline	5	General: Lifeline	<p><u>Device Reset Locally:</u> When factory reset.</p> <p><u>Notification Report:</u> See Notification Chapter for more information.</p> <p><u>Sensor Binary Report:</u> See Param5 for more information.</p> <p><u>Sensor Multilevel Report:</u> When sensors above over limit or below under limit.</p> <p><u>Battery Report:</u> When battery level changed.</p> <p><u>Indicator Report:</u> Issued when the indicator light changed.</p>
2	Motion	5	Notification : Home_Security	<p><u>Basic Set:</u> Basic Set Command will be sent to the associated device when motion trigger or untrigger. The basic set value is determined by Param3. See Param4 for more information.</p>
3	Over Heat	5	Sensor: Temperature	<p><u>Basic Set:</u> When the temperature change value is over or under the threshold set by Param10. Scale is determined by Param24.</p>
4	Under Heat	5	Sensor: Temperature	<p><u>Basic Set:</u> When the temperature change value is under or over the threshold set by Param11. Scale is determined by Param24.</p>
5	Over Light	5	Sensor: Illuminance	<p><u>Basic Set:</u> When the current light/lux is over or under the threshold set by Param12.</p>
6	Under Light	5	Sensor: Illuminance	<p><u>Basic Set:</u> When the current light/lux is under or over the threshold set by Param13.</p>
7	Temperature	5	Sensor: Temperature	Associated device receive Temperature reports from Multi sensor

Basic CC does not map to any Command Class.

3 Wakeup

The device stays in sleep status for the majority of time in order to conserve battery life. The minimum wakeup interval is 1800 seconds (30 minutes)

The maximum wakeup interval is 86400 seconds (24 hours)

The default wakeup interval is 28800 seconds (8 hours) The value is greater, the battery life is longer.

Allowable min step among each wakeup interval is 60 seconds, such as 1860s, 1920s, 1980s...



If the product is in sleep state for a long time and your gateway shows it is in offline state, you can rediscover it via pressing and holding the Action Button for 3 seconds, then the Sensor will send a wake up notification report to your gateway and let your gateway that it is still online.

4 Battery

Battery level will be checked every time the device wakes up. These includes the wake-up timer, motion trigger, button click.

When the battery state changed, a battery report command will be sent to the controller.

5 Multilevel Sensor

The device has a temperature/ humidity sensor and an ambient light sensor. The ambient temperature and light will be checked period.

Command Class	COMMAND_CLASS_SENSOR_MULTILEVEL
Command	SENSOR_MULTILEVEL_REPORT
Type	Air Temperature
Scale	Celsius (EU) / Fahrenheit (US)
Command Class	COMMAND_CLASS_SENSOR_MULTILEVEL
Command	SENSOR_MULTILEVEL_REPORT
Type	Illuminance
Scale	Lux

6 Notification

Notification Type	Notification Event/State	Description
Home Security (0x07)	State idle	Notification value for the state variable going to idle.
	Motion detection (0x08)	When motion triggered.
Power Management (0x08)	Replace battery soon (0x0A)	When battery level below the param14 value.
	Replace battery now (0x0B)	When battery level below 2.4V.
System (0x09)	System software failure (manufacturer proprietary failure code provided) (0x04)	When watch dog timeout.

7 Manufacturer Information

Parameter	Value
Manufacturer ID 1	0x0439
Product Type ID 1	0x0102
Product ID 1	0x0004

8 Configuration

User can change the default settings by the below configuration parameters. After device reset, all these parameters will be set to their default values.

Properties:

R=Readable, W=Writable, S=Signed Integer, U=Unsigned Integer, E=Enumerated, B=Bit field

(Param 3) Motion Retrigger and Untrigger Time

Timeout configuration set in second for motion sensor to send no trigger status. The report time calculate from the last trigger time. Sensor can do retrigger report after the no trigger status report.

Parameter Number	Size (Byte)	Available Settings	Default value	Property
0x03	2	30~3600	240	R/W/U

(Param 4) Motion Sensitivity

Set the sensitivity of motion sensor.

Parameter Number	Size (Byte)	Available Settings	Default value	Property
0x04	1	0~3	3	R/W/U

0 - disable

1 - minimum sensitivity

3 - maximum sensitivity

(Param 5) Motion Report Type

Set which command class will be sent when motion sensor is triggered or dettriggered.

Parameter Number	Size (Byte)	Available Settings	Default value	Property
0x05	1	0/1/2	2	R/W/U

0 - Sends Notification Report

1 - Sends Sensor Binary Report

2 - Sends Notification and Sensor Binary Report

(Param 7) Motion Group Control (Group2)

Set control of other devices on group2 based on motion trigger

Parameter Number	Size (Byte)	Available Settings	Default value	Property
0x07	1	0/1/2/3/4/5/6	0	R/W/E

- 0 - Send BASIC_SET (0xFF) when motion is triggered to associated device
Send BASIC_SET (0x00) when motion is untriggered to associated device
- 1 - Send BASIC_SET (0x00) when motion is triggered
Send BASIC_SET (0xFF) when motion is untriggered
- 2 - Send BASIC_SET (0xFF) when motion is triggered, Nothing when motion untriggered.
- 3 - Send BASIC_SET (0x00) when motion is triggered, Nothing when motion untriggered.
- 4 - Send BASIC_SET (0x00) when motion is untriggered, Nothing when motion triggered.
- 5 - Send BASIC_SET (0xFF) when motion is untriggered, Nothing when motion triggered.
- 6 - Send BASIC_SET (value is configured by parameter 8) when motion is triggered to associated devices.
Send BASIC_SET (value is configured by parameter 8) when motion is untriggered.

(Param 8) Motion Group Value Setting

Set Basic Set value for Group2. The MSB will act as the basic set value when motion trigger. The LSB will act as the basic set value when motion untrigger. E.g. value=0x0A00, then BASIC_SET(0x0A) will be sent when motion trigger, BASIC_SET(0x00) will be sent when motion untrigger.

Parameter Number	Size (Byte)	Available Settings	Default value	Property
0x08	2	0~65535	65280	R/W/U

(Param 9) Motion Group Control Requirement

Set threshold of Light/Lux when devices associated in group2 should be triggered by motion. Associated device only receive BASIC_SET command when light <= (this value).

Parameter Number	Size (Byte)	Available Settings	Default value	Property
0x09	2	0~30000	30000	R/W/U

(Param 10) Over Heat Group Threshold (Group3)

Set threshold of temperature. Designed to control Air Conditioners or temperature controllers ON or OFF. If measured temperature >= (this value, Scale is determined by Param24) send BASIC_SET (0xFF) to associated devices. If measured temperature < (this value) send BASIC_SET (0x00) to associated devices. E.g. Value 239 means 23.9 C. Value 750 means 75.0 F.

Parameter Number	Size (Byte)	Available Settings	Default value	Property
0x0A	2	270~850 (EU/AU) 806~1850 (US)	270 (EU/AU) 806 (US)	R/W/S

0 - Disable.

(Param 11) Under Heat Group Threshold (Group4)

Set threshold of temperature. Designed to control Air Conditioners or temperature controllers ON or OFF. If measured temperature <= (this value, Scale is determined by Param24) send BASIC_SET (0xFF) to associated devices. If measured temperature > (this value) send BASIC_SET (0x00) to associated devices. E.g. Value 155 means 15.5 C. Value 600 means 60.0 F.

Parameter Number	Size (Byte)	Available Settings	Default value	Property
0x0B	2	-100~155 (EU/AU) 140~ 600 (US)	155 (EU/AU) 600 (US)	R/W/S

0 - Disable.

(Param 12) Over Light Group Threshold (Group5)

Set threshold of Light/Lux. If measured light/lux >= (this value) send BASIC_SET (0xFF) to associated devices. If measured light < (this value) send BASIC_SET (0x00) to associated devices.

Parameter Number	Size (Byte)	Available Settings	Default value	Property
0x0C	2	0~30000	2000	R/W/U

0 - Disable.

1 ~ 30000 - Enable. 1 ~ 30000 Lux.

(Param 13) Under Light Group Threshold (Group6)

Set threshold of Light/Lux. If measured light/lux <= (this value) send BASIC_SET (0xFF) to associated devices. If measured light/lux > (this value) send BASIC_SET (0x00) to associated devices.

Parameter Number	Size (Byte)	Available Settings	Default value	Property
0x0D	2	0~30000	100	R/W/U

0 - Disable.

1 ~ 30000 - Enable. 1 ~ 30000 Lux.

(Param 14) Low Battery Threshold

Configure low battery report threshold, sends low battery report via notification and battery report when battery level drops under setting. Unit %.

Parameter Number	Size (Byte)	Available Settings	Default value	Property
0x0E	1	10~50	20	R/W/U

(Param 15) Threshold Check Enable/Disable

Parameter Number	Size (Byte)	Available Settings	Default value	Property
0x0F	1	0/1	0	R/W/E

0 - disable threshold reports

1 - enable threshold reports

(Param 16) Temperature Threshold

Threshold = (Value * 0.1) 0 = disable.

Parameter Number	Size (Byte)	Available Settings	Default value	Property
0x10	1	0~255	30	R/W/U

(Param 17) Lux Threshold

0 = disable.

Parameter Number	Size (Byte)	Available Settings	Default value	Property
0x11	2	0~10000	250	R/W/U

(Param 18) Threshold Check Time

Set threshold, upper and lower limit check time in seconds.

Parameter Number	Size (Byte)	Available Settings	Default value	Property
0x12	2	60~65535	900	R/W/U

60~65535 - Battery powered

(Param 19) Sensor Limit Control

This value is bit mask. Used to enable/disable measurement reports for various sensors that is more than the upper limit value or less than the lower limit value.

Parameter Number	Size (Byte)	Available Settings	Default value	Property
0x13	1	1 2 3 4 5 6 7 8 9 10 11 12 13 14 15	0	R/W/B

0 - Disabled

1 - Temperature upper level

2 - Lux upper level

4 - Temperature lower level

8 - Lux lower level

Note: this parameter supports combination setting. E.g. if value = 1+2+4+8=15, which means all the limit reports are enabled.

(Param 20) Temperature Upper Limit

Set upper limit level for temperature set in scale of 0.1. Scale is determined by Param24. If (Current measurement) > (Upper Limit), then report sensor.

Parameter Number	Size (Byte)	Available Settings	Default value	Property
0x14	2	280~1000 (EU/AU)	280 (EU/AU)	R/W/S
		824~2120 (US)	824 (US)	

(Param 21) Temperature Lower Limit

Set lower limit level for temperature set in scale of 0.1. Scale is determined by Param24. If (Current Measurement) < (Lower limit), then report sensor.

Parameter Number	Size (Byte)	Available Settings	Default value	Property
0x15	2	-400~0 (EU/AU)	0 (EU/AU)	R/W/S
		-400~320 (US)	320 (US)	

(Param 22) Lux Upper Limit

Set lux upper limit level. If (Current measurement) > (Upper Limit), then report sensor.

Parameter Number	Size (Byte)	Available Settings	Default value	Property
0x16	2	0~30000	1000	R/W/U

(Param 23) Set lux lower limit level.

Set lux lower limit level. If (Current Measurement) < (Lower limit), then report sensor.

Parameter Number	Size (Byte)	Available Settings	Default value	Property
0x17	2	0~30000	100	R/W/U

(Param 24) Temperature Scale

Set the scale for temperature when reports.

Parameter Number	Size (Byte)	Available Settings	Default value	Property
0x18	1	0/1	0 (EU/AU) 1 (US)	R/W/E

0 - Celsius

1 – Fahrenheit

(Param 25) Automatic Interval Time

Interval time set in seconds to check the sensor report. Multilevel Sensor Report will be sent when timeout.

Parameter Number	Size (Byte)	Available Settings	Default value	Property
0x19	2	30~65535	3600	R/W/U

(Param 26) LED Activity

Allow user to enable/disable LED activity of specific reports sent by sensor. Button press indicator is not affected by this.

Parameter Number	Size (Byte)	Available Settings	Default value	Property
0x1A	1	0/1	1	R/W/E

0 - disable

1 - enable

(Param 27) Motion Sensor Report Indicator

If LED is enabled by Param81, allow user to change the report color of motion sensor.

Parameter Number	Size (Byte)	Available Settings	Default value	Property
0x1B	1	0/1/2/3/4/5/6/7/8/9	3	R/W/E

0 - Disabled

1 - Red

2 - Blue

3 - Green

4 - Pink

5 - Cyan

6 - Purple

7 - Orange

8 - Yellow

9 - White

(Param 28) Temperature Offset Value

Can add or minus this setting value to calibrate temperature when checked. Scale is defined by Param24. e.g. Value 15 means 1.5C or 1.5F.

Parameter Number	Size (Byte)	Available Settings	Default value	Property
0x1C	2	-200 ~200	0	R/W/S

(Param 29) Lux Offset Value

Can add or minus this setting value to calibrate Lux when checked.

Parameter Number	Size (Byte)	Available Settings	Default value	Property
0x1D	2	-10000~10000	0	R/W/S

9 Security Network

This device is a security enabled Z-Wave Plus product that is able to use encrypted Z-Wave Plus messages to communicate to other security enabled Z-Wave Plus products.

The device supports the security function with S0 and S2 encrypted communication. The device will auto switch to the security mode when the device included with a security controller. In the security mode, the commands will use security and security2 command class wrapped to communicate with others, otherwise the device will not response any commands.

This device supports security levels are listed in belowtable:

Security Levels	Support (Yes/No)
SECURITY_KEY_S0	Yes
SECURITY_KEY_S2_UNAUTHENTICATED	Yes
SECURITY_KEY_S2_AUTHENTICATED	Yes
SECURITY_KEY_S2_ACCESS	No